

Punch Information [ Note (1) ]	
Description	Example
Job Reference	EU XXXX
Material	XXXX
Connection	XXXX
Length	XXXX mm
Tag No.	XXXX
Heat No.	HT XXXX
Stem Heat No.	S-HT XXXX
Serial No.	S.N XXXX

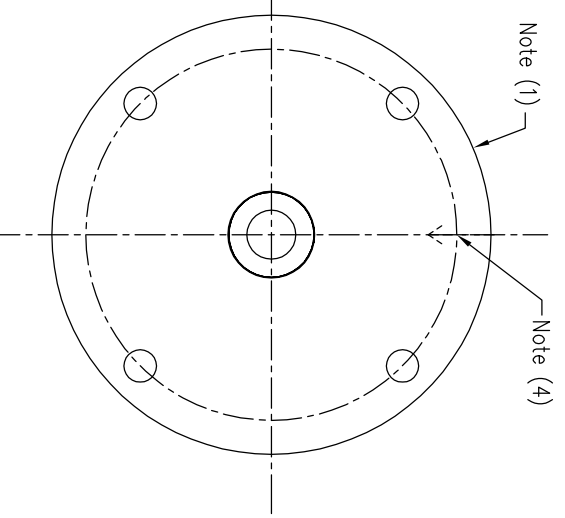

- Note (1) : Punch on the ring of the flange
- Note (2) : Full penetration weld requires to have min. pipe sch80.
- Note (3) : Clean internally from welding mark and dusts
- Note (4) : Direction of flow (Pls follow process flow direction)
- Note (5) : Number of bolt holes will be depend on flange rating

Sample probe, Flange Type, Both RTU	
Tolerance	Length < 1 mtr ( $\pm 1$ mm), 1 mtr < Length ( $\pm 2$ mm) < 2 mtr
CUSTOMER	
Wa: Lin	Toe Toe Lwin
QUOTATION NO.	
ASSP-08-14	
<p><b>ACEZ SENSING PTE LTD</b>                  28E PENJURU CLOSE, #01-04                  SINGAPORE 609133                  TEL: 65-6265 1588 FAX : 65-6264 3992                  Website : www.acezsensing.com</p>	

S/N	DESCRIPTION	A.S PART NO.	MATERIAL	QTY.	REMARK
2	Flange				
1	Seamless Pipe				