

If in doubt – Ask

Dimensions in Millimeters Unless Otherwise Stated

Do Not Scale This Drawing

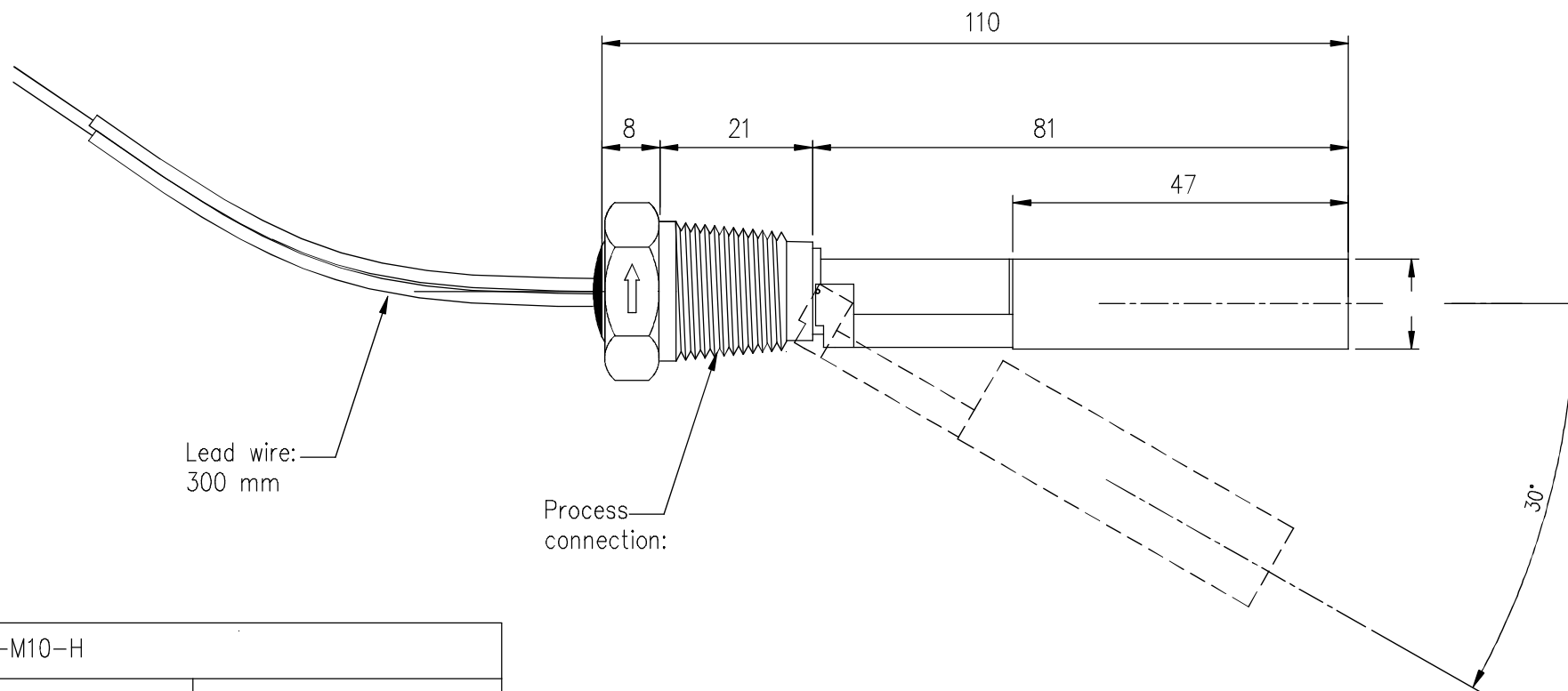

MODEL : MFS-M10-H

1	Switching Capacity Max.	50 W/ SPST
2	Switching Voltage Max.	240 VAC/ 200 VDC
3	Switching Current Max.	0.5 A
4	Carry Current Max.	1 A
5	Lead Wire	XLPE AWG 22
6	Maximum Pressure	5 Kg/cm ²
7	Operating Temperature	-20°C to 120°C
8	Material	SUS 304
9	Suitable Specific Gravity	0.92
10	Process Connection	1/2" PT

Mini Float Switch

Tolerance	Length < 1 mtr (±1mm), 1 mtr < Length (±2mm) < 2 mtr		
CUSTOMER			
Wai Lin	Toe Toe Lwin	QUOTATION NO.	
DRAWN BY	APPROVED BY	STD DWG NO.	MFS-M10-H

ACEZ SENSING PTE LTD

28E PENJURU CLOSE, #01-04
SINGAPORE 609133

TEL: 65-6265 1588 FAX : 65-6264 3992

Website : www.acezsensing.com