

If in doubt – Ask

Dimensions in Millimeters Unless Otherwise Stated

Do Not Scale This Drawing

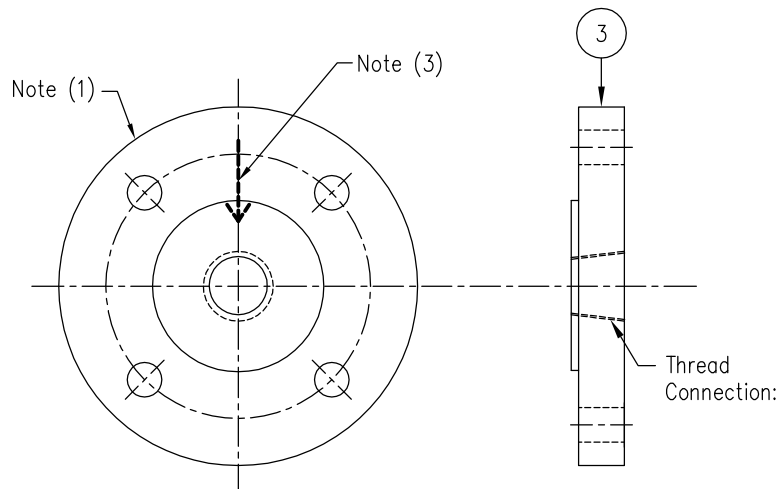

Punch Information[Note (1)]	
Description	Example
Job Reference	EIJ XXXX
Material	XXXX
Connection	XXXX
Length	XXXX mm
Tag No.	XXXX
Heat No.	HT XXXX
Stem Heat No.	S.HT XXXX
Serial No.	S.N XXXX

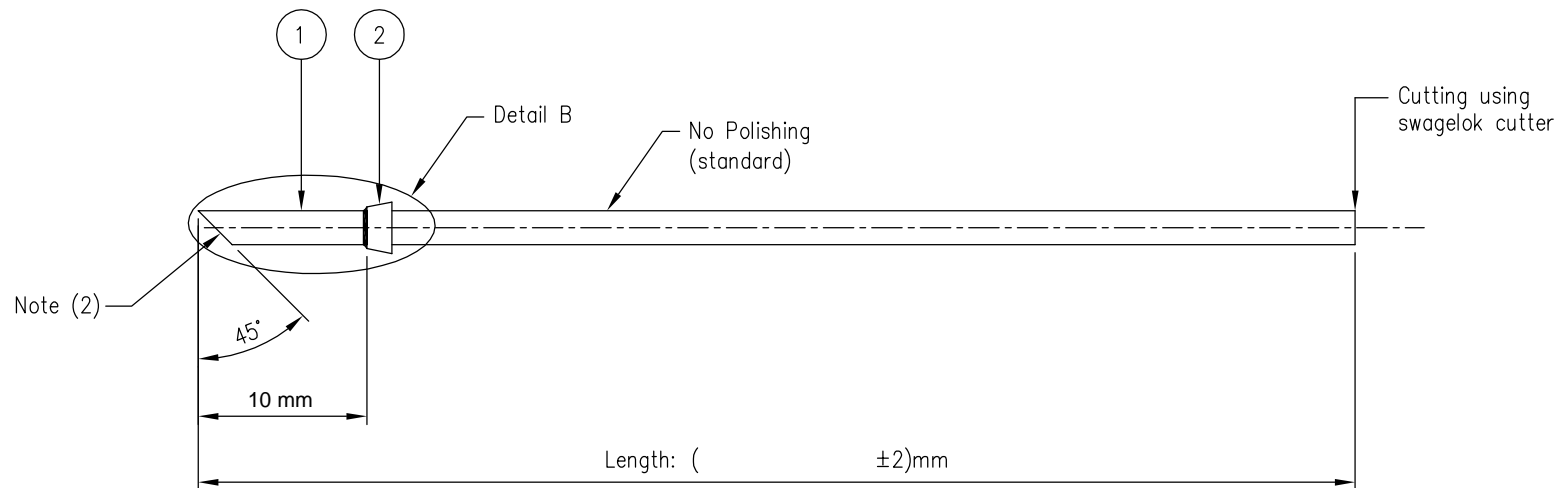
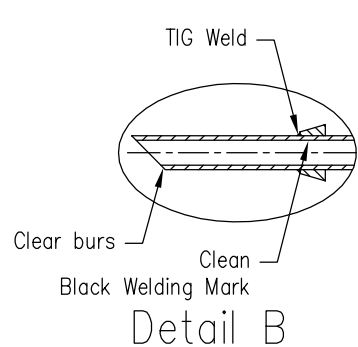

- Note (1) : Punch on the ring of the flange
- Note (2) : Clean internally from welding mark and dusts
- Note (3) : Direction of flow (Pls follow process flow direction)
- Note (4) : Number of bolt holes will be depend on flange rating

Retractable Sample Probe

3	Flange					Tolerance	Length < 1 mtr (±1mm), 1 mtr < Length (±2mm) < 2 mtr		ACEZ SENSING PTE LTD 28E PENJURU CLOSE, #01-04 SINGAPORE 609133 TEL: 65-6265 1588 FAX : 65-6264 3992 Website : www.acezsensing.com
2	Ferrule					CUSTOMER			
1	Tube Size					Wai Lin	Toe Toe Lwin	QUOTATION NO.	
S/N	DESCRIPTION	A.S PART NO.	MATERIAL	QTY.	REMARK	DRAWN BY	APPROVED BY	DWG NO.	RP-01